

BARRANCA SERIES (CEILING)

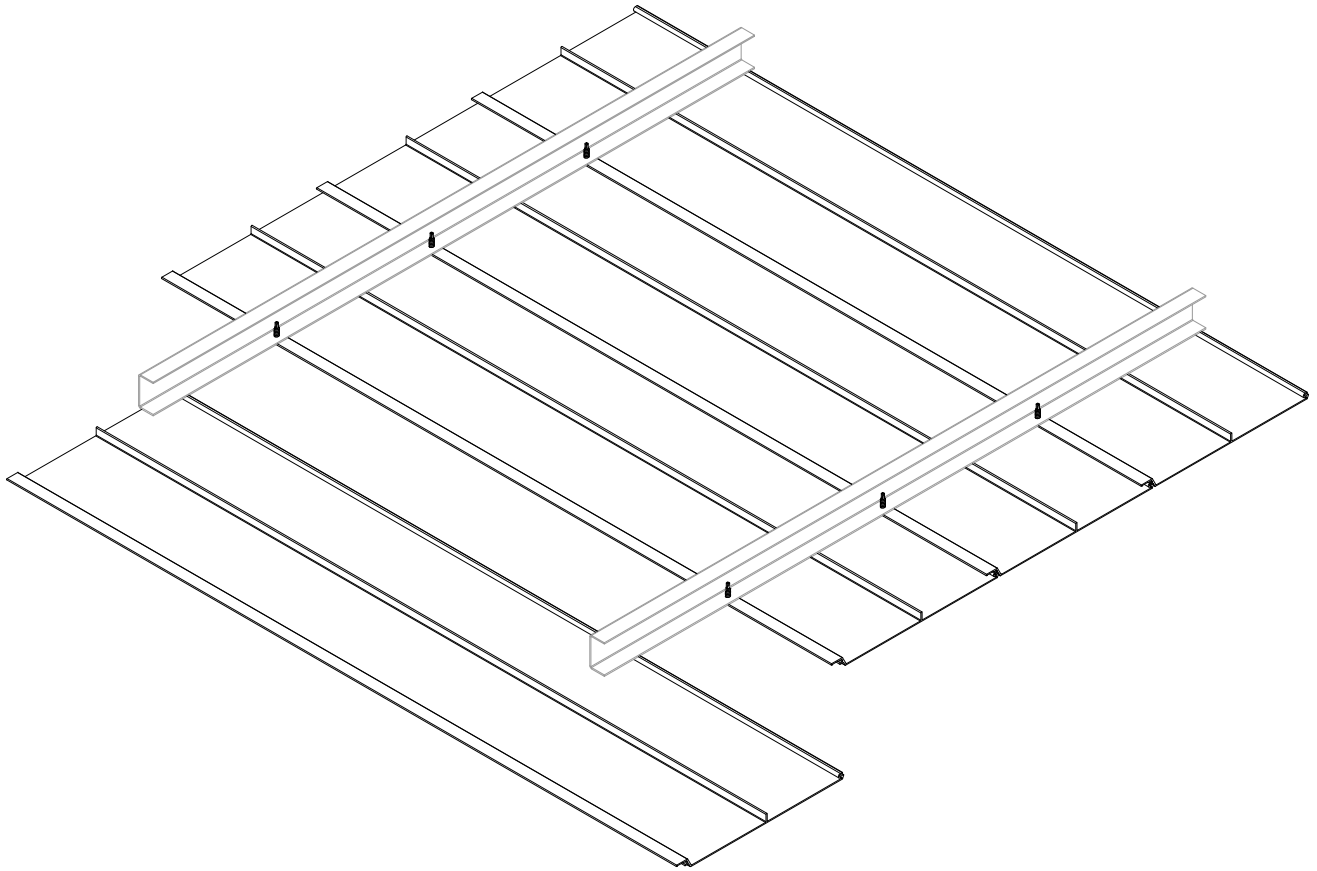

EXTERIOR INTERIOR DSCSP01

**Any copy hereof issued by CARRITEC must be kept confidential and used by the recipient only for the specific purpose for which it is issued in conjunction with materials supplied or purchased and listed hereon.*

**Dimensions are imperial.*



BARRANCA SERIES (CEILING)

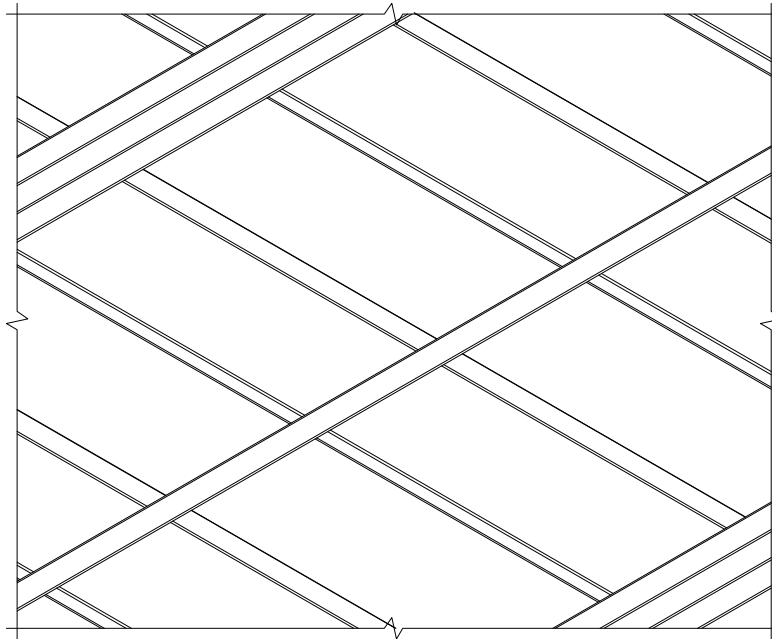

ISOMETRIC VIEW

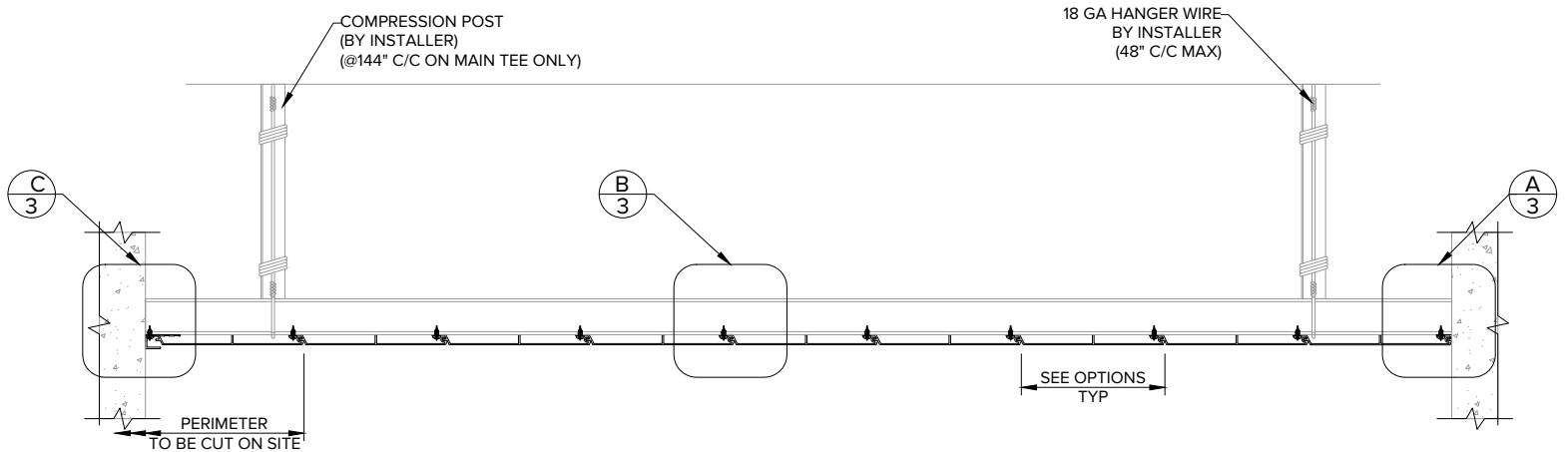

TRANSVERSAL SECTION

EXTERIOR INTERIOR DSCSP01

*Any copy hereof issued by CARRITEC must be kept confidential and used by the recipient only for the specific purpose for which it is issued in conjunction with materials supplied or purchased and listed hereon.

*Dimensions are imperial.

TOLERANCES (UNLESS OTHERWISE SPECIFIED):

FRACTIONS: +1/64

ANGLES: ± 0.5

DECIMALS: - .XX ± 0.03

- .XXX ± 0.015



BARRANCA SERIES (CEILING)

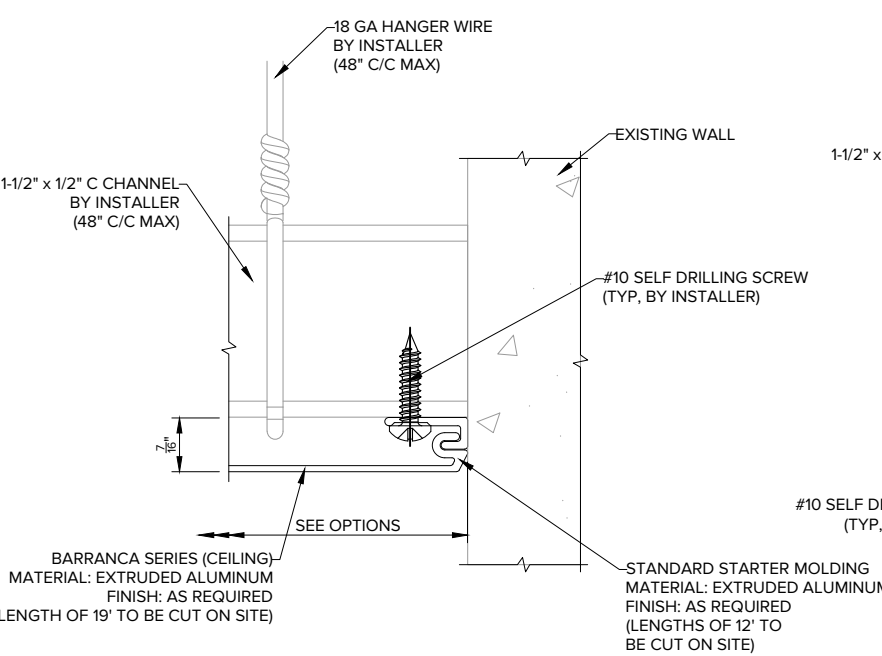

DETAIL A
STARTING CONDITION

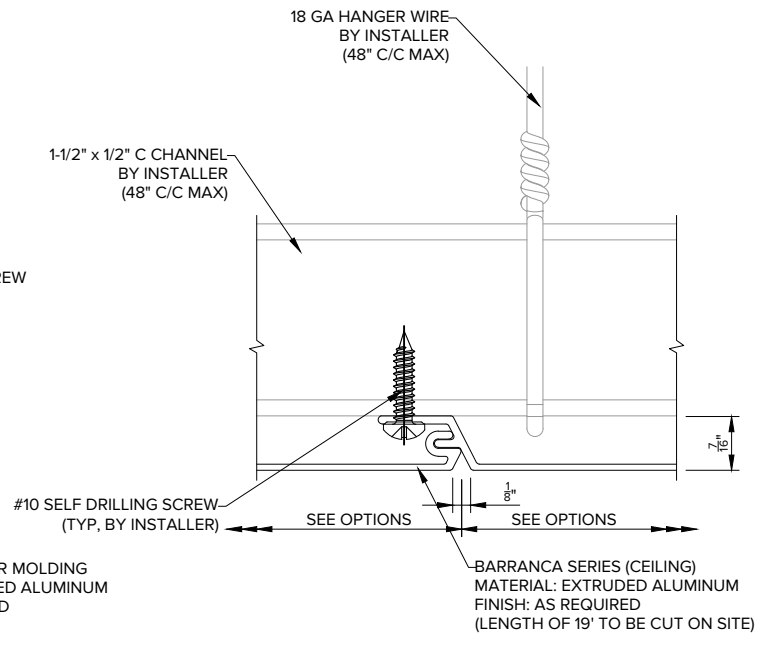

DETAIL B
TYP. JOINT CONDITION

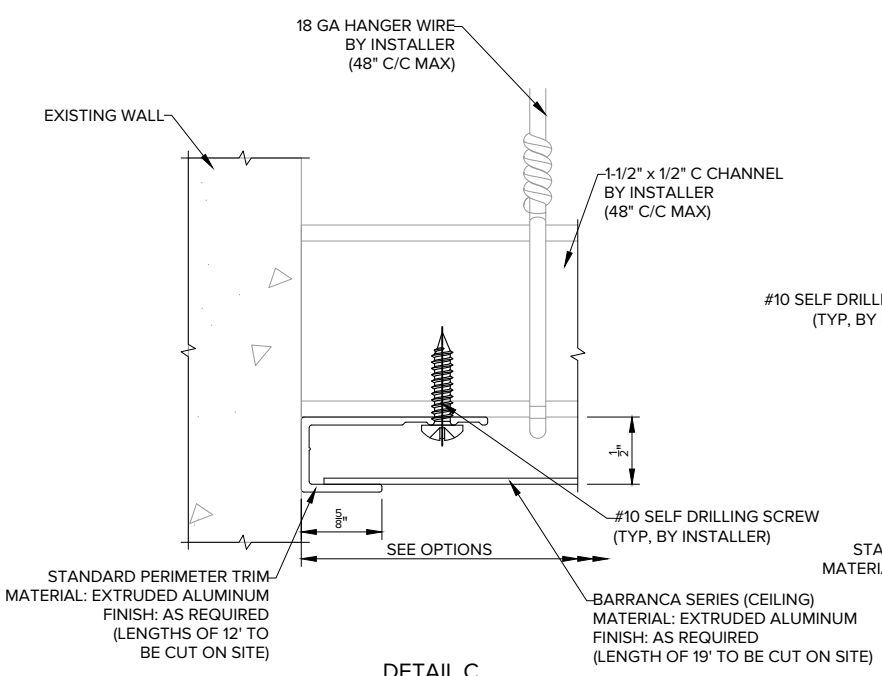

DETAIL C
WALL TO WALL CONDITION

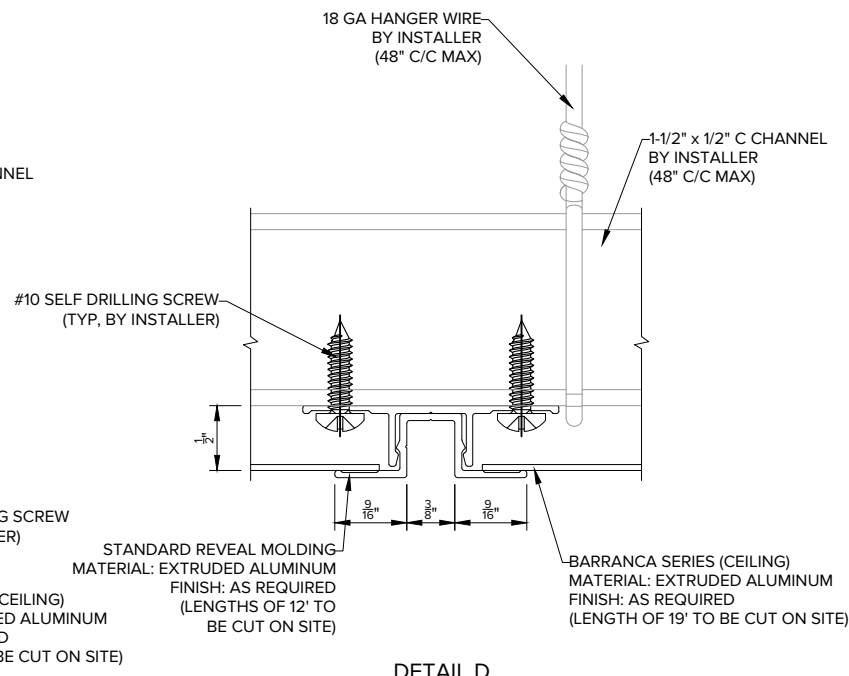

DETAIL D
REVEAL COVER

EXTERIOR INTERIOR DSCSP01

*Any copy hereof issued by CARRITEC must be kept confidential and used by the recipient only for the specific purpose for which it is issued in conjunction with materials supplied or purchased and listed hereon.

*Dimensions are imperial.

TOLERANCES (UNLESS OTHERWISE SPECIFIED):
 FRACTIONS: +1/64
 ANGLES: ± 0.5
 DECIMALS: -.XX ± 0.03
 -.XXX ± 0.015



BARRANCA SERIES (CEILING)

STANDARD PLANK
WIDTH OPTIONS

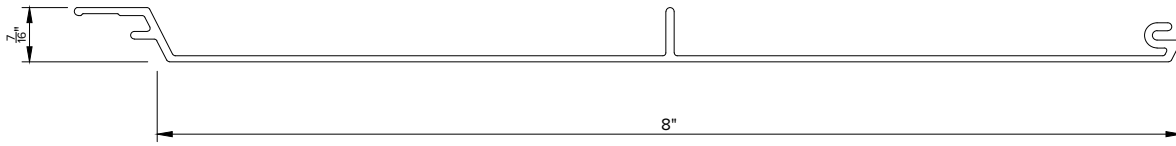

OPTION A
8 INCH PLANK

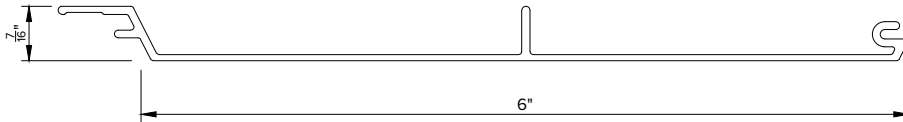

OPTION B
6 INCH PLANK

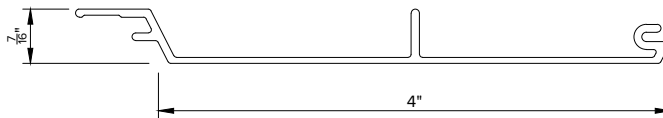

OPTION C
4 INCH PLANK

EXTERIOR INTERIOR DSCSP01

**Any copy hereof issued by CARRITEC must be kept confidential and used by the recipient only for the specific purpose for which it is issued in conjunction with materials supplied or purchased and listed hereon.*

**Dimensions are imperial.*

TOLERANCES (UNLESS OTHERWISE SPECIFIED):

FRACTIONS: +1/64

ANGLES: ± 0.5

DECIMALS: -.XX ± 0.03

-.XXX ± 0.015

