

CUMULUS SERIES (CEILING)

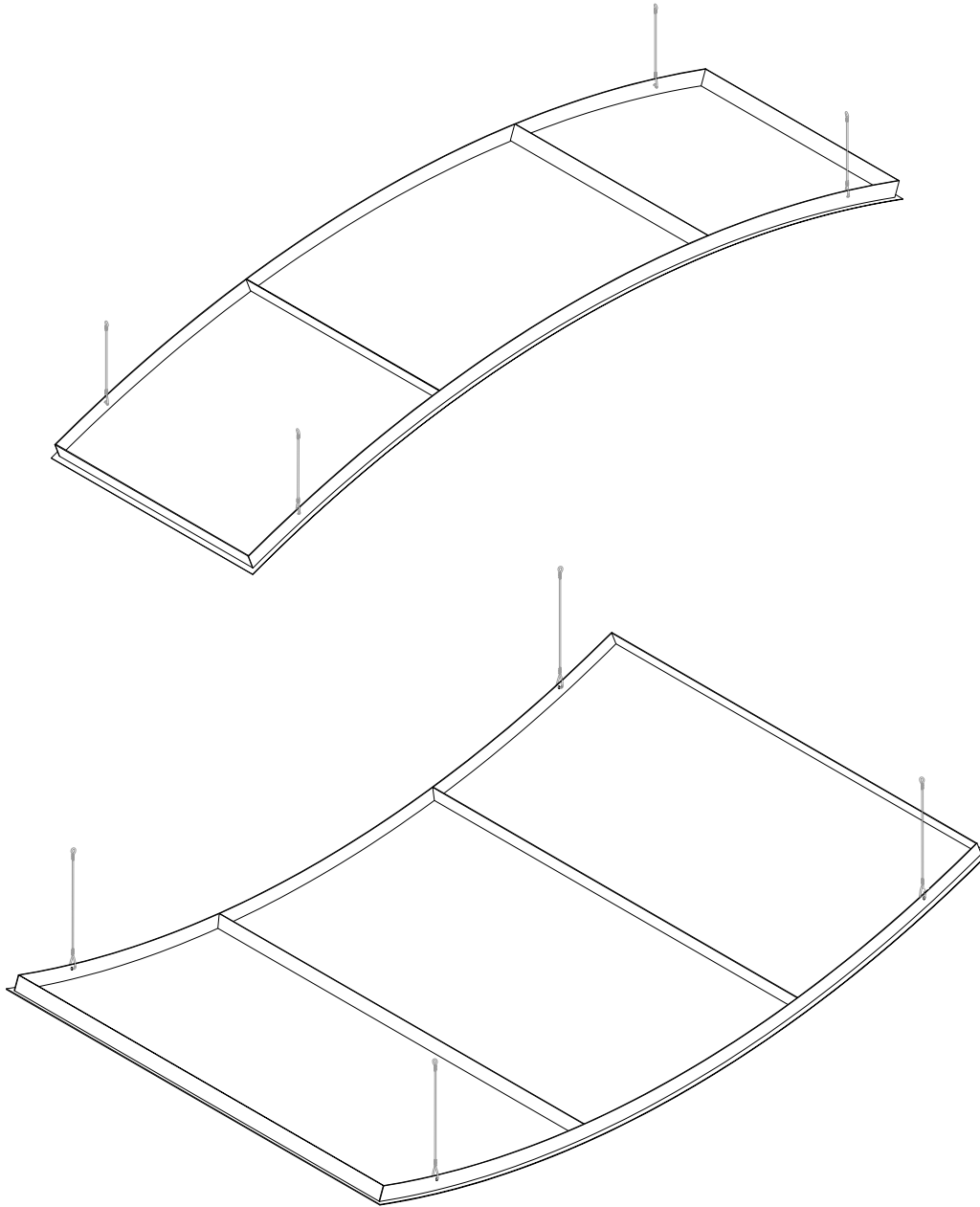

EXTERIOR INTERIOR DSCSP15

**Any copy hereof issued by CARRITEC must be kept confidential and used by the recipient only for the specific purpose for which it is issued in conjunction with materials supplied or purchased and listed hereon.*

**Dimensions are imperial.*



CUMULUS SERIES (CEILING)

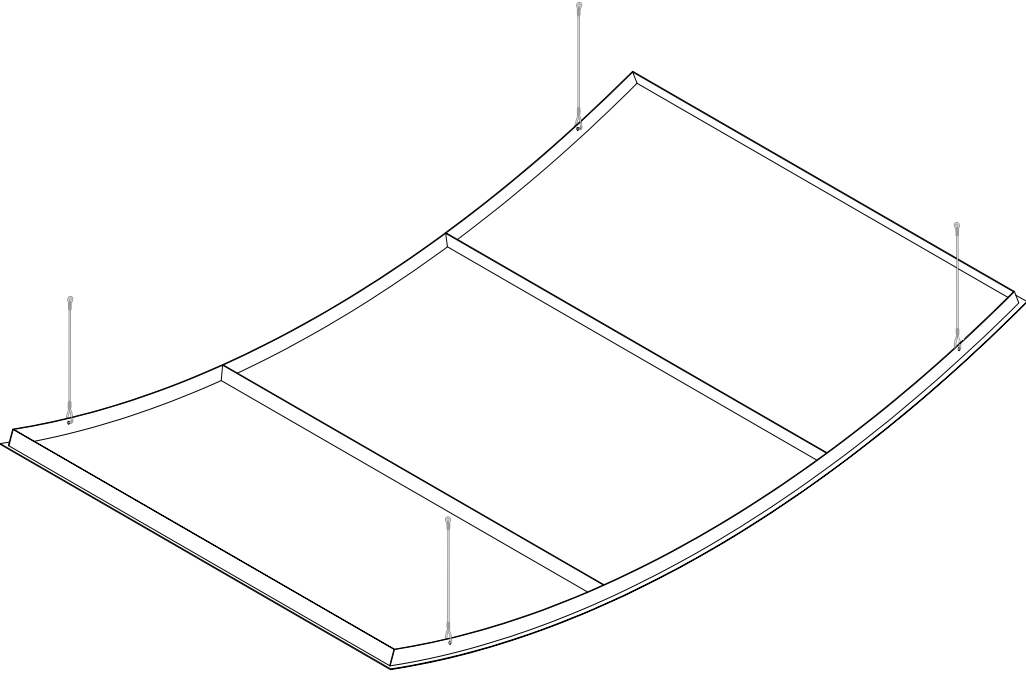

ISOMETRIC VIEW

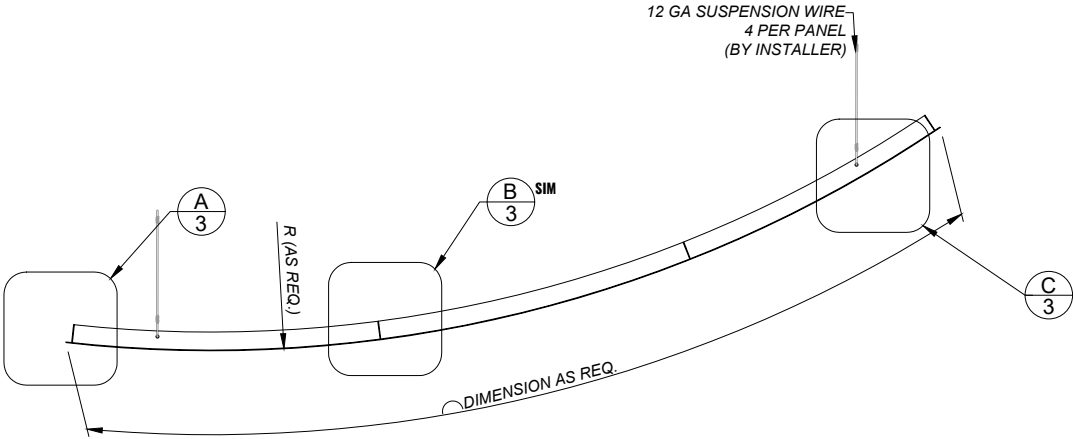

TRANSVERSAL SECTION

EXTERIOR INTERIOR DSCSP15

*Any copy hereof issued by CARRITEC must be kept confidential and used by the recipient only for the specific purpose for which it is issued in conjunction with materials supplied or purchased and listed hereon.

*Dimensions are imperial.

TOLERANCES (UNLESS OTHERWISE SPECIFIED):
 FRACTIONS: +1/64
 ANGLES: ± 0.5
 DECIMALS: - .XX ± 0.03
 - .XXX ± 0.015



CUMULUS SERIES (CEILING)

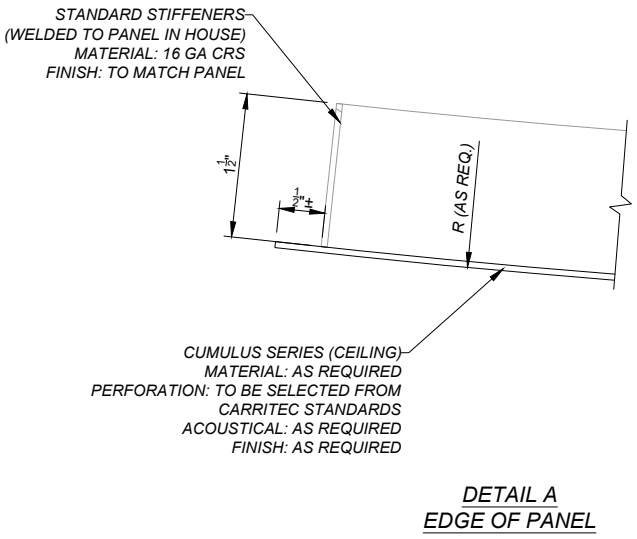

DETAIL A
EDGE OF PANEL

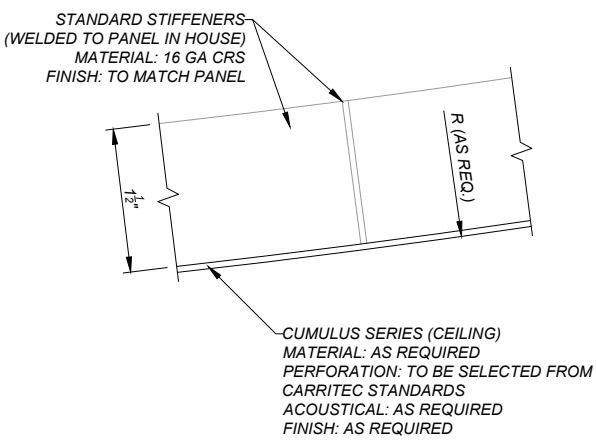

DETAIL B
STIFFENER DETAIL

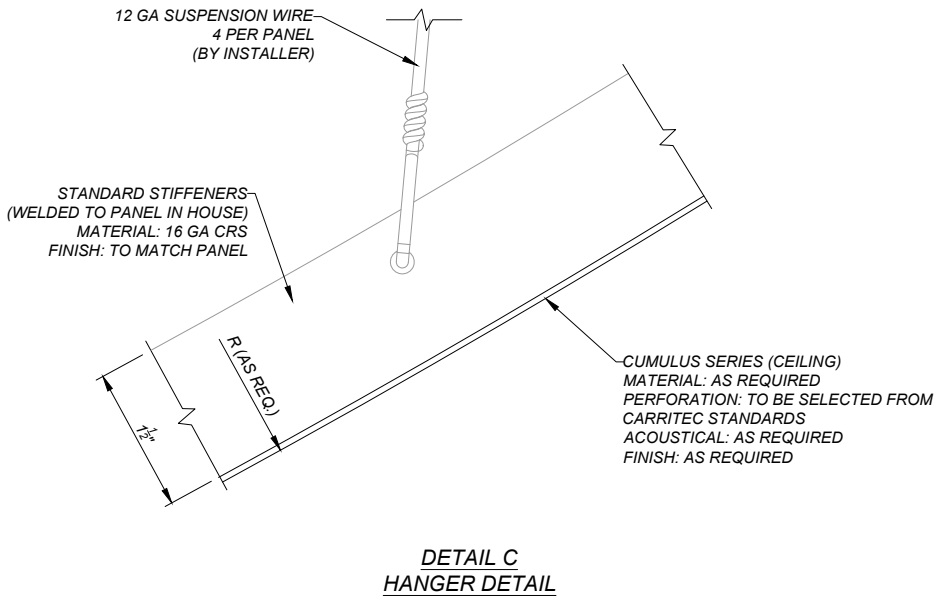

DETAIL C
HANGER DETAIL

EXTERIOR INTERIOR DSCSP15

*Any copy hereof issued by CARRITEC must be kept confidential and used by the recipient only for the specific purpose for which it is issued in conjunction with materials supplied or purchased and listed hereon.

*Dimensions are imperial.

TOLERANCES (UNLESS OTHERWISE SPECIFIED):
 FRACTIONS: +1/64
 ANGLES: ± 0.5
 DECIMALS: -.XX ± 0.03
 - .XXX ± 0.015

