

# STRONG HAVEN SECURE SERIES (CEILING)

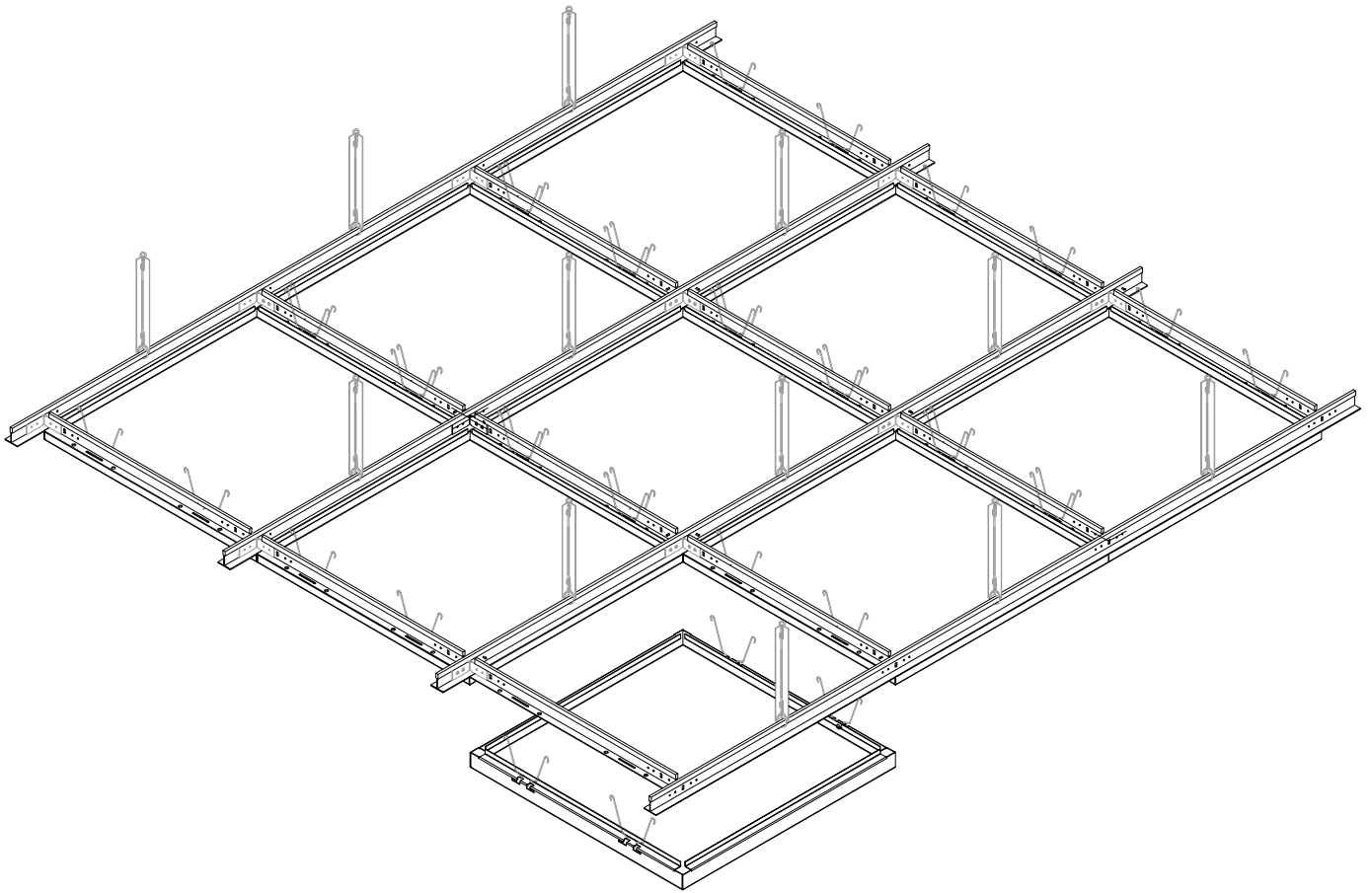

EXTERIOR  INTERIOR  DSCSP06.1

\*Any copy hereof issued by CARRITEC must be kept confidential and used by the recipient only for the specific purpose for which it is issued in conjunction with materials supplied or purchased and listed hereon.

\*Dimensions are imperial.



# STRONG HAVEN SECURE SERIES (CEILING)

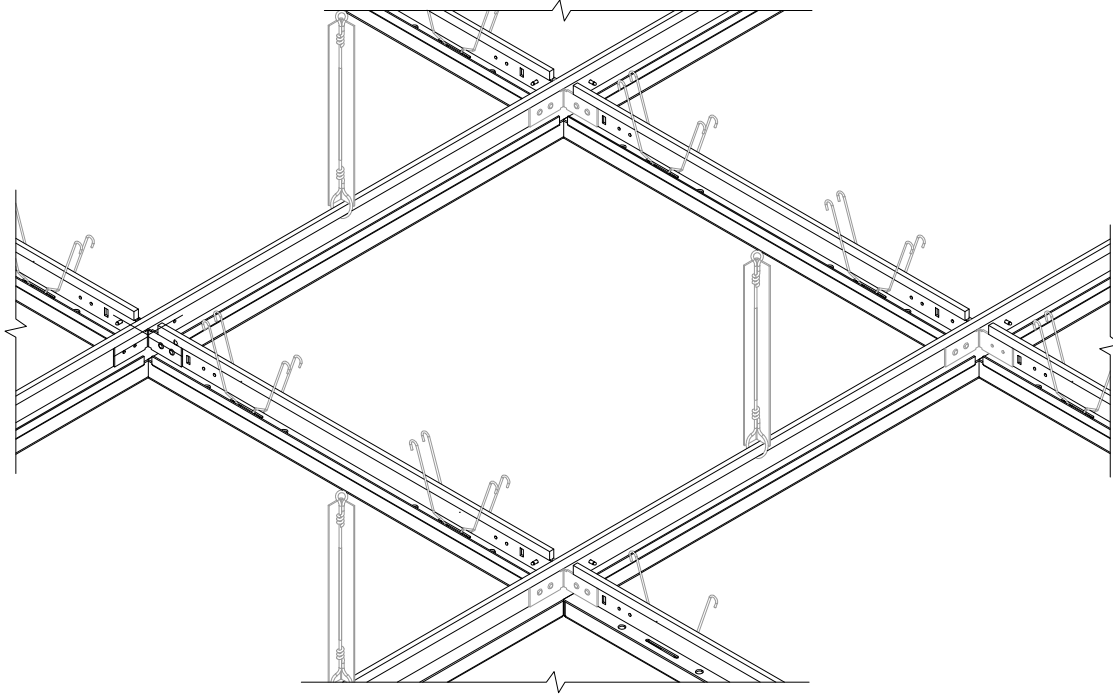

ISOMETRIC VIEW

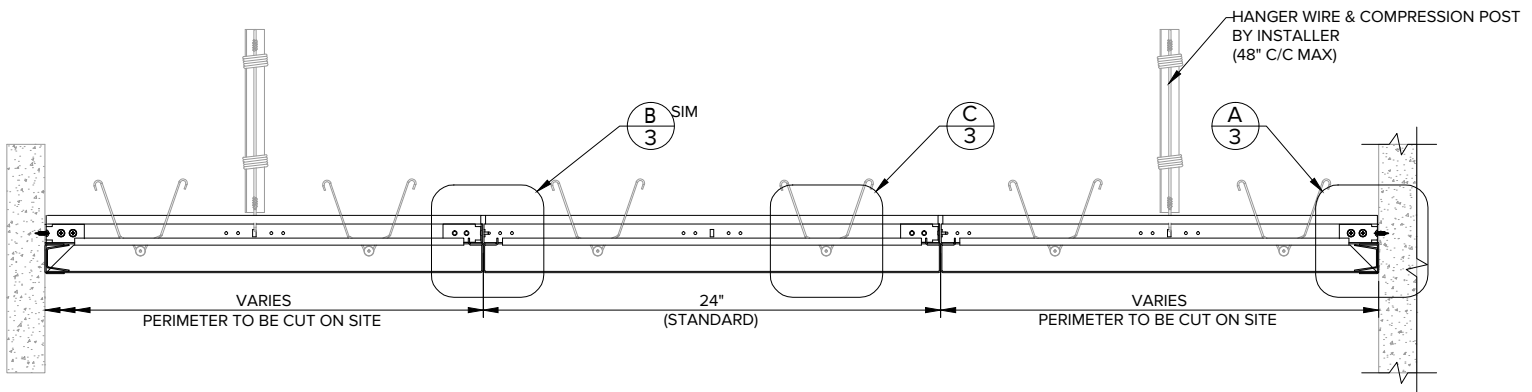

TRANSVERSAL SECTION

EXTERIOR  INTERIOR  DSCSP06.1

\*Any copy hereof issued by CARRITEC must be kept confidential and used by the recipient only for the specific purpose for which it is issued in conjunction with materials supplied or purchased and listed hereon.

\*Dimensions are imperial.

TOLERANCES (UNLESS OTHERWISE SPECIFIED):

FRACTIONS: +1/64  
 ANGLES: ± 0.5  
 DECIMALS: -.XX ± 0.03  
 -.XXX ± 0.015



# STRONG HAVEN SECURE SERIES (CEILING)

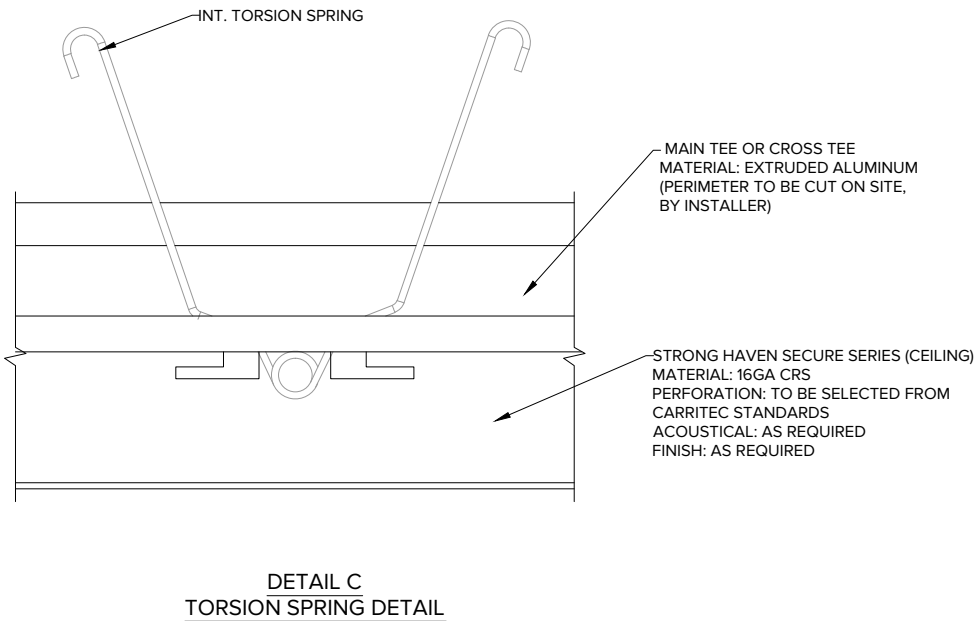
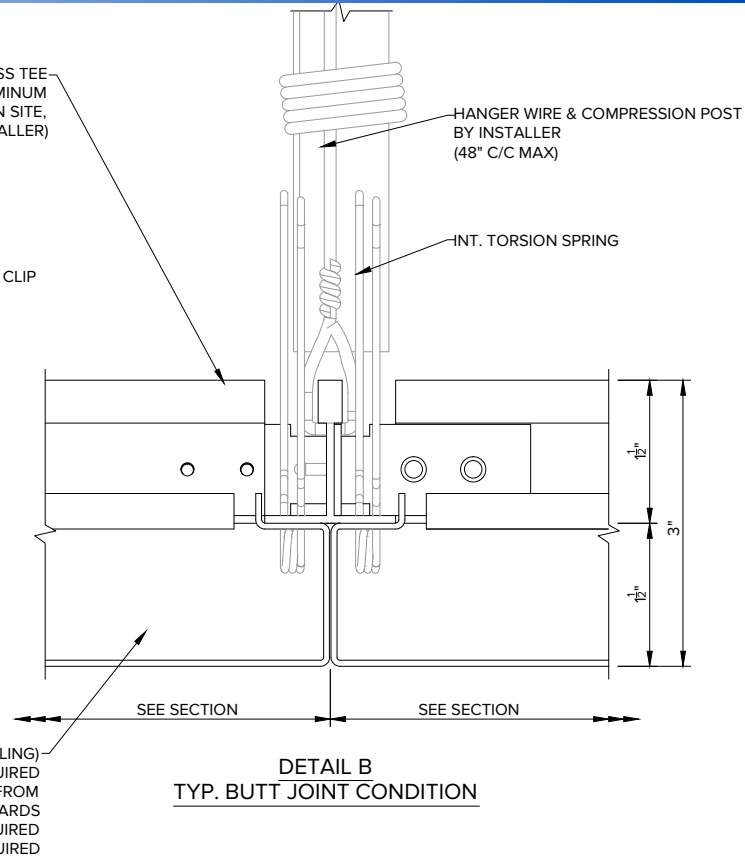
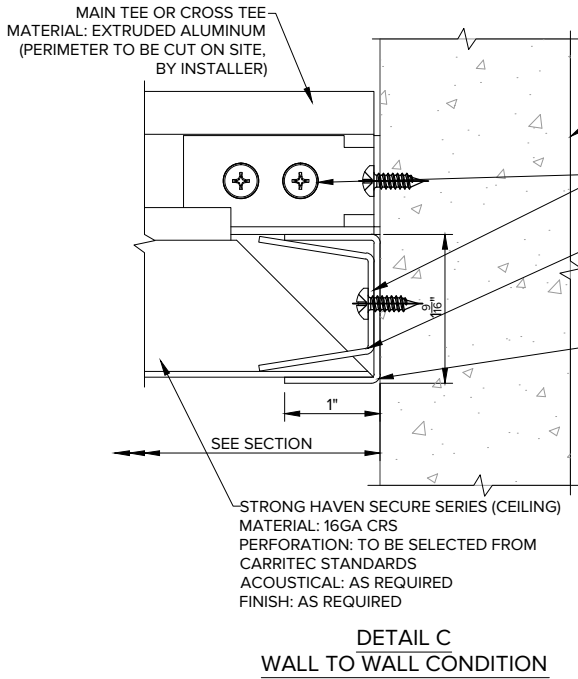

EXTERIOR  INTERIOR  DSCSP06.1

\*Any copy hereof issued by CARRITEC must be kept confidential and used by the recipient only for the specific purpose for which it is issued in conjunction with materials supplied or purchased and listed hereon.

\*Dimensions are imperial.

TOLERANCES (UNLESS OTHERWISE SPECIFIED):

FRACTIONS: +1/64  
 ANGLES: ± 0.5  
 DECIMALS: -.XX ± 0.03  
 -.XXX ± 0.015

